

# Ścisk wzmacniony

706



## Cechy produktu

- materiał: stal węglowa premium flex plus
- całość hartowana i odpuszczana
- drewniany uchwyt, lakierowany



## Zalety:

- zintegrowany hamulec zapobiega niekontrolowanemu przesuwaniu się
- maksymalna siła ścisku 6000N
- profil przesuwny ząbkowany
- obrotowa podkładka dociskowa

## Użycie:

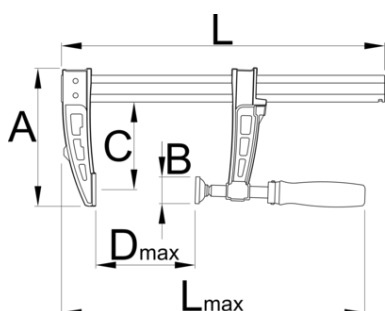
- do stosowania w stolarstwie, spawalnictwie i montażu



		$D\uparrow$	L	$L\uparrow$	A	C	B	
626283	200	200	323	465	181	136	34	1750
626284	300	300	423	565	181	136	34	1870
626285	400	400	523	665	181	136	34	2090
626286	500	500	623	765	181	136	34	2310
626287	600	600	723	865	181	136	34	2530
626288	1000	1000	1123	1265	181	136	34	3410

\* Przedstawiony wygląd produktu jest orientacyjny. Wszystkie wymiary są w mm, podana waga w gramach

## Użycie (Obrazy)



Przesuwna szczęka z wieloma możliwościami pozycjonowania.

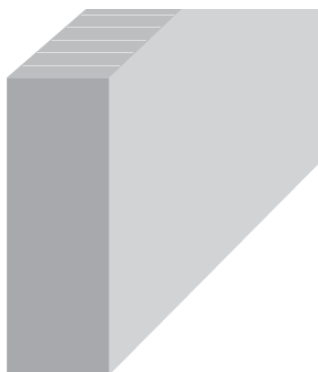

Profilowana szyna prostokątna ze stali o wysokiej wytrzymałości, kalibrowana i ząbkowana. Wykończenie powierzchni: szczęki lakierowane, szyna ocynkowana.



Śruba z gwintem trapezowym: „Mniej wysiłku – większa siła mocowania”.



Obrotowa stopa



