

Strettoio per impieghi gravosi

706



Attributi del prodotto

- materiale: acciaio al carbonio plus flex premium
- interamente bonificato
- impugnatura di legno, laccata



Vantaggi:

- il freno integrato evita lo slittamento incontrollato
- forza di serraggio massima: 6000 N
- profilo scorrevole scanalato
- tazza girevole

Utilizzo:

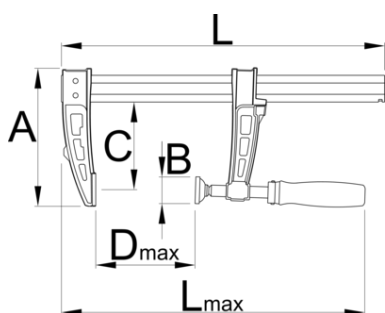
- per uso in carpenteria, saldatura e assemblaggio



		$D\uparrow$	L	$L\uparrow$	A	C	B	
626283	200	200	323	465	181	136	34	1750
626284	300	300	423	565	181	136	34	1870
626285	400	400	523	665	181	136	34	2090
626286	500	500	623	765	181	136	34	2310
626287	600	600	723	865	181	136	34	2530
626288	1000	1000	1123	1265	181	136	34	3410

* Le immagini dei prodotti sono puramente simboliche. Tutte le dimensioni sono in mm, peso in grammi.

Utilizzo (pictures)



Ganascia scorrevole con più possibilità di posizionamento.

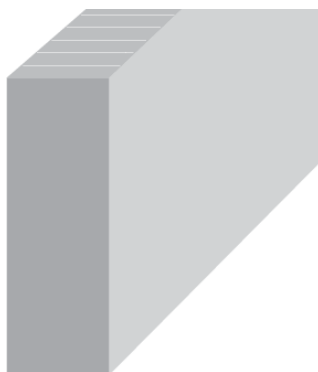

Guida profilata rettangolare in acciaio ad alta resistenza, calibrata e scanalata. Finitura superficiale: ganasce laccate, guida zincata.



Vite con filettatura trapezoidale: "Minore sforzo-maggiore forza di serraggio".



Piede orientabile



