

Rezač cevi

360/6B



Opis proizvoda

- brza zamena sečiva
- ergonomska ručka
- 4 rolera za bolje prijanjanje na cev i lakšu upotrebu
- rezervni točak za sečenje unutar ručke
- moguće korišćenje NOGA alata za ravnjanje površina reza
- sistem brzog pomeranja

Upotreba:

- za sečenje bakarnih, aluminijumskih, inox i čeličnih cevi maksimalne debljine od 2 mm

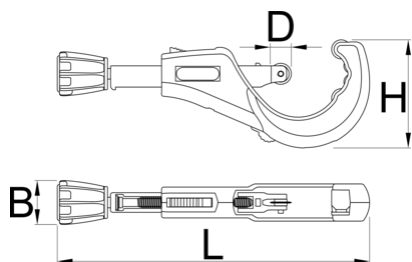

626188



6 - 76



1/4" - 3"

B

41.4

D

19.8

H

1018



245



334



890

* Fotografije proizvoda su simbolične. Sve dimenzije su u mm, a težina u gramima. Sve navedene dimenzije mogu odstupati u granicama tolerancija.

Upotreba (slike)



4 rolera za bolje prijanjanje na cev i lakšu upotrebu

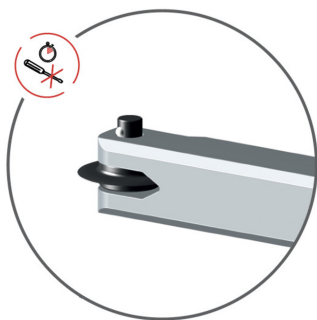

brza zamena sečiva

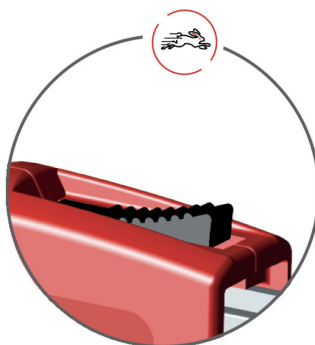

sistem brzog pomeranja

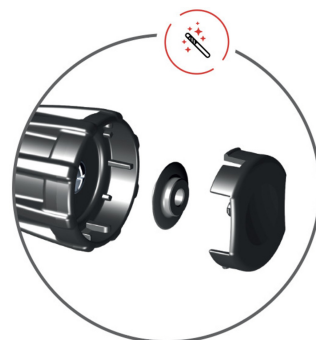

rezervni točak za sečenje unutar ručke



moguće korišćenje NOGA alata za ravnjanje površina reza

Rezervni delovi



Rezervni nožić

Povezani proizvodi



Rezač cevi



Rezač cevi



Rezač cevi