

Angle impact wrench

1564



Profiles



Product features

- free speed 8000 revolution per minutes

- max. torque 343 Nm
- recommended air pressure: 6,2 Bar
- air consumption 113 l/min
- air inlet 1/4"
- noise level 92 dB(A)
- max bolt size M16

Advantages:

- aluminium motor housing
- composite handle
- handle exhaust (silencer)
- one hand forward / reverse
- compact and powerful
- jumbo hammer mechanism





Usage:

- car industry
- aircraft industry
- agricultural equipment
- heavy industry
- larger construction machinery
- shipbuilding industry
- individual mounting

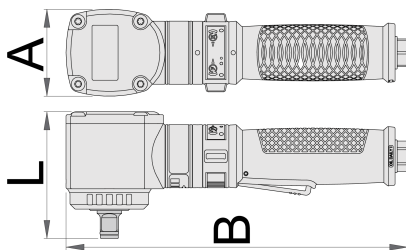
Important!

- Always use Unior IMPACT sockets.



		L	A	B		
627569	1/2"	88	60	237	343	1332

* Images of products are symbolic. All dimensions are in mm, and weight in grams. All listed dimensions may vary in tolerance.

Usage (pictures)



Photo (pictures)



Accessories



Coupling, male part



Coupling, male part



Coupling, female part



Coupling, female part



Pneumatic filter regulator and lubricator 3/8"



Pneumatic filter regulator and lubricator 1/2"



Spiral pneumatic hose

Safety tips



- The pressure in the tool during the operation has to be at least 6.2 bar for the tool to work properly.
- Regularly clean and dry the air filters and inlet air supply.
- Always use clean and dry air with the correct mixture of oil, for maximum tool life.
- Check the joints and ensure that the tubes and other equipment are not damaged before use.
- All tools should be gently oiled prior to being stored.
- Always store pneumatic tools in dry places away from water.
- Always use original spare parts.
- Repairs can be performed only by authorised staff people authorised by Unior d.d.
- Always disconnect tools not in use from the air supply.