

darbe anahtarı

1563



Profiles



Product features

- serbest hız dakikadaki devir sayısı 8000
- mak. tork 745 Nm
- önerilen hava basıncı: 6, 2 Bar

- hava tüketimi 164 l / dak
- hava girişi 1/4"
- Gürültü seviyesi 104dB (A)
- max bolt size M20

Avantajları:

- kompozit motor gövdesi
- egzoz kolu (susturucu)
- bir yandan ileri / geri
- kompakt ve güçlü
- jumbo çekiç mekanizması





Kullanım:

- araba sanayi
- uçak sanayi
- tarım ekipmanı
- ağır sanayi
- büyük inşaat makineleri
- gemi inşaat sanayisi
- bireysel montaj

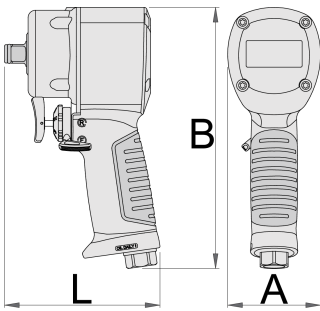
Önemli!

- Her zaman Unior DARBELİ lokmalarını kullanın.



		L	A	B		
627568	1/2"	105,4	63	177	745	1329

* Ürünlerin resimleri semboliktir. Bütün boyutlar mm ve ağırlık gram cinsindedir.

Usage (pictures)



Photo (pictures)



Accessories



bağlantı elemanı, erkek parça



Bağlantı elemanı, erkek parça



bağlantı elemanı, dişi parça



Bağlantı elemanı, dişi parça



Pnömatik filtre düzenleme ve yağlama aleti 3/8"



Pnömatik filtre düzenleme ve yağlama aleti 1/2"



Spiral pnömatik hortum

Safety tips



- The pressure in the tool during the operation has to be at least 6.2 bar for the tool to work properly.
- Regularly clean and dry the air filters and inlet air supply.
- Always use clean and dry air with the correct mixture of oil, for maximum tool life.
- Check the joints and ensure that the tubes and other equipment are not damaged before use.
- All tools should be gently oiled prior to being stored.
- Always store pneumatic tools in dry places away from water.
- Always use original spare parts.
- Repairs can be performed only by authorised staff people authorised by Unior d.d.
- Always disconnect tools not in use from the air supply.