

Odvrtič pneumatski, kompozitni, prihvat 1/2"

1563



Profili



Opis proizvoda

- 8.000 o/min u slobodnom hodu

- max. obrtni moment: 745 Nm
- preporučeni pritisak dovoda vazduha: 6,2 bar
- potrošnja komprimovanog vazduha: 164 l/min
- priključak za vazduh: 1/4"
- nivo buke: 104dB(A)
- za vijke do M20

Prednosti:

- kompozitno kućište
- sa izduvom na rukohvatu za tiši rad
- laka i brza promena smeru jednom rukom
- kompaktan i snažan
- jednostruki udarni mehanizam JUMBO

Upotreba:

- auto-industrija
- avio-industrija
- poljoprivredna mehanizacija
- teška industrija
- veće građevinske mašine
- brodogradnja
- individualna montaža

VAŽNO!

- UVEK koristite Uniorove IMPACT nasadne ključeve i pribor

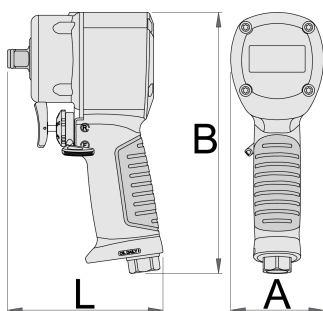

		L	A	B		
627568	1/2"	105,4	63	177	745	1329

* Fotografije proizvoda su simbolične. Sve dimenzije su u mm, a težina u gramima. Sve navedene dimenzije mogu odstupati u granicama tolerancija.

Upotreba (slike)



Slika (slike)



Dodatna oprema



Spojnica muška



Spojnica muška



Spojnica ženska



Spojnica ženska



Pripremna grupa za pneumatski alat 3/8"



Pripremna grupa za pneumatski alat 1/2"



Crevo spiralno za vazduh

Pravilna upotreba



- The pressure in the tool during the operation has to be at least 6.2 bar for the tool to work properly.
- Regularly clean and dry the air filters and inlet air supply.
- Always use clean and dry air with the correct mixture of oil, for maximum tool life.
- Check the joints and ensure that the tubes and other equipment are not damaged before use.
- All tools should be gently oiled prior to being stored.
- Always store pneumatic tools in dry places away from water.
- Always use original spare parts.
- Repairs can be performed only by authorised staff people authorised by Unior d.d.
- Always disconnect tools not in use from the air supply.