

Slagmoersleutel 1/2", kort model

1563



Profielen



Product attributen

- free speed 8000 revolution per minutes
- max. torque 745 Nm
- recommended air pressure: 6,2 Bar

- air consumption 164 l/min
- air inlet 1/4"
- noise level 104dB(A)
- max bolt size M20

Voordelen:

- composite motor housing
- handle exhaust (silencer)
- one hand forward / reverse
- compact and powerful
- jumbo hammer mechanism





Gebruik:

- car industry
- aircraft industry
- agricultural equipment
- heavy industry
- larger construction machinery
- shipbuilding industry
- individual mounting

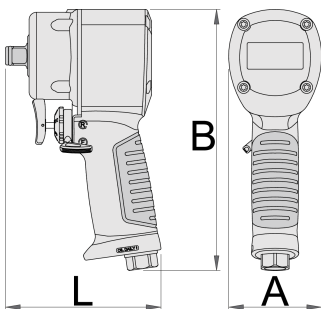
Important!

- Always use Unior IMPACT sockets.



| | | | | | | |
|--|---|----------|----------|----------|---|---|
|  |  | L | A | B |  |  |
| 627568 | 1/2" | 105,4 | 63 | 177 | 745 | 1329 |

* Afbeeldingen van producten zijn symbolisch. Alle afmetingen zijn in mm en gewicht in gram. Alle vermelde afmetingen kunnen variëren in tolerantie.

Gebruik (Afbeeldingen)



Foto (Afbeeldingen)



Accessoires



Koppeling, man



Koppeling, man



Koppeling, vrouw



Koppeling, vrouw



Pneumatische filterdrukregelaar en olieverniveelaar 3/8"



Pneumatische filterdrukregelaar en olieverniveelaar 1/2"



Spiraalslang

Veiligheidstips



- The pressure in the tool during the operation has to be at least 6.2 bar for the tool to work properly.
- Regularly clean and dry the air filters and inlet air supply.
- Always use clean and dry air with the correct mixture of oil, for maximum tool life.
- Check the joints and ensure that the tubes and other equipment are not damaged before use.
- All tools should be gently oiled prior to being stored.
- Always store pneumatic tools in dry places away from water.
- Always use original spare parts.
- Repairs can be performed only by authorised staff people authorised by Unior d.d.
- Always disconnect tools not in use from the air supply.