

Chiave tripla a brugola a Y

1781/2HX-US



Profili



Attributi del prodotto

- L'impugnatura in plastica iniettata offre una presa comoda e compatta, che permette di lavorare in maniera efficiente mentre il materiale di alta qualità garantisce una lunga durata dell'utensile

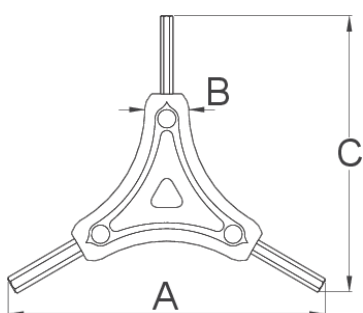



A

B

C



624908	2	2,5	3	122	16	106	36
624909	4	5	6	122	16	106	65

* Le immagini dei prodotti sono puramente simboliche. Tutte le dimensioni sono in mm, peso in grammi.

Utilizzo (pictures)

