

Clé six pans à trois bras

1781/2HX-US



Profils



Description produit

- La poignée en plastique injectée donne une prise compacte et confortable permettant ainsi un travail efficace, alors que le matériau haute qualité assure à l'outil une grande longévité.

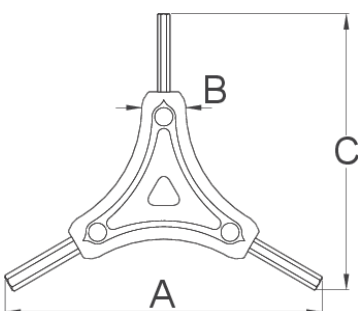



A

B

C



624908

2

2,5

3

122

16

106

36

624909

4

5

6

122

16

106

65

* Les images des produits ne sont pas contractuelles. Toutes les dimensions sont en mm, les poids en grammes.

Utilisation (pictures)

