

# Çekan pneumatik me goditje

1514



## Profiles



## Product features

- përdorur për prerje fletë, bulonave dhe largimin e skorje saldim, thumba, suva dhe pllaka
- me pranverë, ndryshim të shpejtë shërbyes si pjesë këmbimi
- pistoni gjatësia goditje: 170 - 67mm, 225 - 92mm
- lindi diametër 9,1 mm
- goditje për minutë: 170 - 3000, 225 - 2100
- konsumi i ajrit 250 l / min
- gji ajrit 1/4 "



## Avantazhet:

- të lehta dhe kompakt mjet, përdorur edhe në dhoma të vogla
- gamë të gjerë të përdorimit
- ndryshojë mbajtëse

## Përdorim:

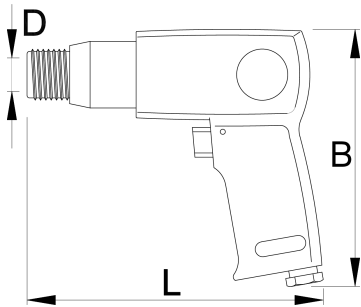
- industria e makinave
- prerja e fletë metalike dhe vida
- heqja e saldimit
- duke punuar në mure, konkrete, gurë, tulla, çeliku, metalet e lehta



	L	B	D	
617714	170	150	19	1810
617715	225	150	19	2160

\* Imazhet e produkteve janë simbolike. Të gjitha dimensionet janë në mm, pesha në gram. Të gjitha dimensionet e listuara mund të ndryshojnë në tolerancë.

## Usage (pictures)



## Photo (pictures)



## Accessories



Spirale për 1514



Mbajtës i ndërrimit të shpejtë për 1514



Daltë e rrafshët



Daltë me majë



Daltë për copëza metali



Daltë për prerjen e llamarinës



Daltë me formë V



Daltë e gjerë



Lidhëse mashkullore



Lidhëse mashkullore



Lidhëse femore



Lidhëse femore



Rregullatori pneumatik i filtrit dhe lubrifikuesi 3/8"



Rregullatori pneumatik i filtrit dhe lubrifikuesi 1/2"



Gyp I ajrit spiral

## Safety tips



- The pressure in the tool during the operation has to be at least 6.2 bar for the tool to work properly.
- Regularly clean and dry the air filters and inlet air supply.
- Always use clean and dry air with the correct mixture of oil, for maximum tool life.



- Always disconnect tools not in use from the air supply.

- Check the joints and ensure that the tubes and other equipment are not damaged before use.
- All tools should be gently oiled prior to being stored.
- Always store pneumatic tools in dry places away from water.
- Always use original spare parts.
- Repairs can be performed only by authorised staff people authorised by Unior d.d.