

# Portable truing stand

1688



## Profiles

---



## Product features

- material: premium flex plus carbon steel

- It is possible to center wheels with dimension from 16 to 29 inch, with or without tire.
- Supports hubs up to 157 mm width.
- This stand is intended especially for the enthusiast. It is very easy to use, light (2.3 kg) and does not take up much space. The left bracket is fixed and welded to the lower profile, while the right bracket is flexible to different all axle widths.

#### How to use the tool:

- The stand can be folded by folding the leg to the lower profile.
- The stand can also be mounted on the work bench with screws to increase stability.
- The control sensor is single sided so first the wheel shall be centered on one side, then turned around and centered on the other side.
- The additional function enables true checking of wheel discs.

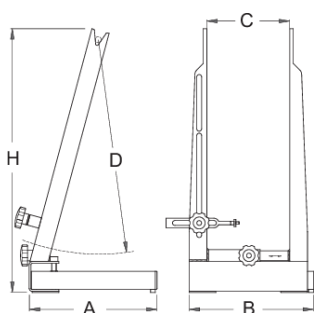

				<b>A</b>	<b>B</b>	<b>H</b>	
623060	760	90	172	218	217	463	2300

\* Images of products are symbolic. All dimensions are in mm, and weight in grams. All listed dimensions may vary in tolerance.

#### Usage (pictures)

