

Centreur de roues professionnel

1689



Profils



Description produit

We redesigned many of its features. The base has been made stronger for improved precision and we also added conical one-size-fits-all magnetic thru-axles adapters that can be stored anywhere on the base. The arms have been made longer to accommodate 29+ wheels better and the calipers widened accordingly. Threads, springs and bearings were all revised resulting in smoother operation plus less frequent calibration. Additionally, we include white high-gloss stickers you can apply to the base and caliper arm to improve background contrast, making it easier than ever to use.

Here is a full list of the improvements.

- Stronger base for improved precision
- Longer and redesigned upright arms for improved clearance of 29+ wheels and truing precision
- Wider calipers for increased clearance of 29+ wheels
- Accommodates wider axles, works with through axle hubs up to 197mm width (include the use of adapters). Max. arm opening 230mm (without the use of adapters).
- New bearings on the upright arm adjust axle are spring loaded for improved precision and reduced frequency of calibration
- Redesigned caliper tips for easier radial truing
- Revised threads and springs for smoother operation
- 8mm bench mount holes at the bottom, 268 mm center to center
- Slicker design, all black
- Comes with conical magnetic through axle adapters – one size fits all (12, 15 and 20). The adapters are now magnetic and can be affixed anywhere on the base. Features a bolt for more permanent fix on the upright arms.
- Includes white high gloss stickers, covering the base and caliper arm, for improved background contrast (stickers are not preapplied)

Compatibility:

- Accepts wheels from 16 to 29+ inch with or without tire.
- Supports solid, quick release and through axle hubs
- Through axle hubs are supported with use of the adapters (included with truing stand)
- One pair of through axle adapters support all sizes of through axles

Standard features (same as before):

- La géométrie des étriers permet un contrôle simultané axial pour le dressage exacte de la roue.
- Palpeurs en plastique pour ne pas rayer les flancs de la jante
- La position verticale des bras peut être ajustée avec un bouton de réglage de la position verticale pour convenir à la largeur de l'essieu. La position du bras étrier peut être ajustée pour s'adapter au rayon de la roue et la distance de l'étrier de mesure peut être ajustée pour s'adapter à la largeur de la jante.
- Lors du changement de la roue, le bras à ressort et le bras de mesure peuvent être retirés rapidement, revenant automatiquement à une position définie pour l'insertion d'une nouvelle roue. Cela permet un centrage rapide de plusieurs roues de même taille.

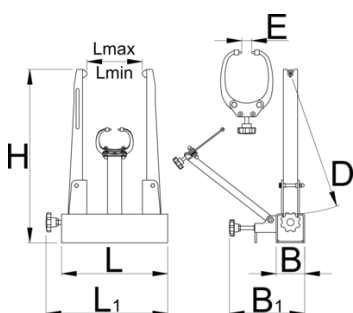



D↑

E↑

L↓

L↑

H

L

L1



629297

390

40

40

226

485

298

342

7165

* Les images des produits ne sont pas contractuelles. Toutes les dimensions sont en mm, les poids en grammes.

Utilisation (pictures)

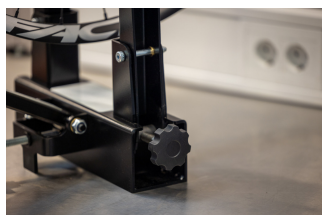
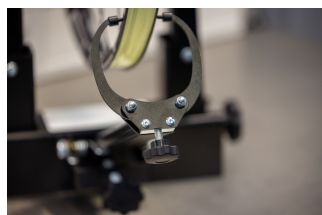

Accessories



Bras de contrôle de mesure pour 1689



Étrier de frein pour 1689



Adaptateur pour essieu de roues

 Adaptateur Cannondale Lefty® pour centreur de roues



Pro Truing Stand Wooden Base

Pièces de rechange



Embout de rechange pour étrier



Manche pour 1689