

Coffret de tournevis à frapper 1/2"

6762



Profils









Description produit

- Dimensions du box: 197 x 105 x 38

Le jeu comprend :

- 1x tournevis à frapper (article 6762.1) dim. 1/2"
- 1x adaptateur (article 6762.2) dim. 1/2"-5/16"
- 2x embouts pour vis 6 pans (article 6489C8) dim. 5, 6
- 4x embouts pour vis Torx (article 6492C8) dim. TX20, TX25, TX30, TX40
- 1x embouts pour vis PHILLIPS (article 6484C8) dim. PH4
- 2x embouts pour vis PHILLIPS (article 6483C8) dim. PH2, PH3
- 3x embouts pour vis à fente (article 6480C8) dim. 1.2x6.5x41, 1.6x8.0x41, 2.0x12.0x41

Nom du produit	SKU	Article	Dimensions	Quantité
Coffret de tournevis à frapper 1/2"	605061	6762	-	14
Embouts pour vis à fente		6480C8	1.2 x 6.5x41, 1.6 x 8.0x41, 2.0 x 12.0x41	3
Embouts pour vis PHILLIPS		6483C8	PH 2, PH 3	2
Embouts pour vis PHILLIPS		6484C8	PH 4	1
Embouts pour vis 6 pans		6489C8	5, 6	2
Embouts pour vis Torx		6492C8	TX 25, TX 30, TX 40, TX 20	4
Tournevis à frapper		6762.1	1/2"x144	1
Adaptateur 1/2"-5/16"		6762.2	1/2" - 5/16"	1

* Les images des produits ne sont pas contractuelles. Toutes les dimensions sont en mm, les poids en grammes.

Utilisation (pictures)

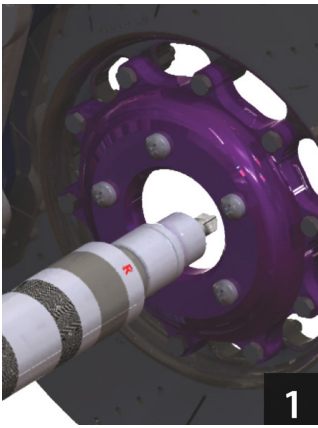

Move impact screwdriver closer to screw, which we will tighten (R), or loosen (L)

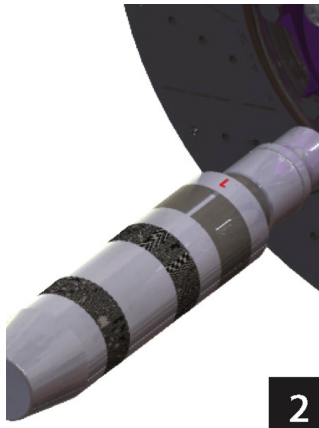

L is showing screw loosening.

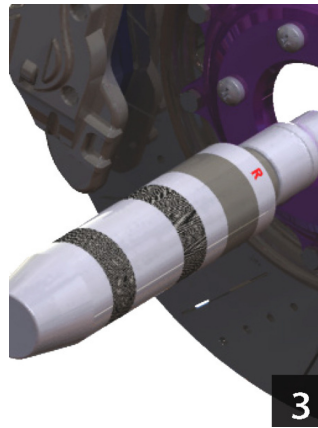

R is showing screw tightening.

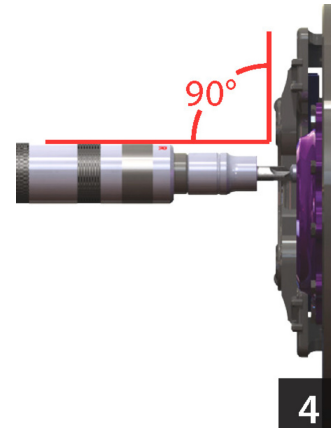

When tightening or loosening the screw, tool has to be placed in a position perpendicular to the screw!

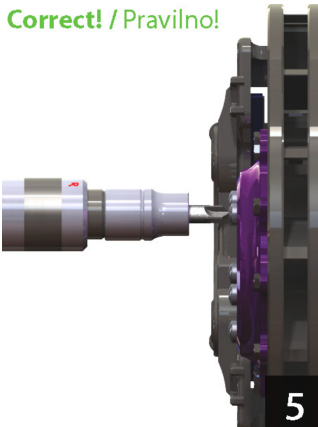

Move tool closer to screw, and don't press it to final position before use. With hammer strike, tool is automatically extracted and tightening/loosening begins.

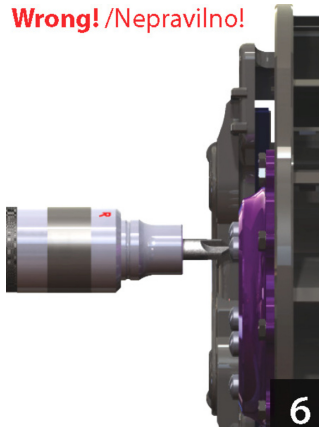

When the tool is in the compressed position, and we strike it with hammer inner mechanism will get destroyed. Never strike tool with hammer, when the tool is in compressed position!

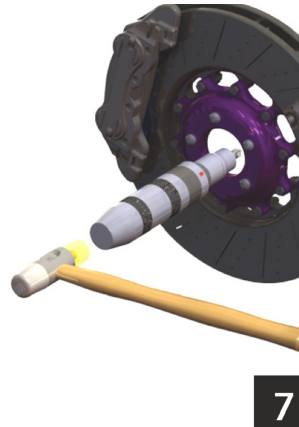

When the tool is properly positioned on the screw, tap the tool holder with hammer. This will trigger mechanism that allows bolt tightening/loosening for approx. 15°.