

Elektricien's tas

909/1



Product attributen

- Materiaal : kunstleer 650 g, voering zak 450 g
- slot, ringen, klinknagels, gesp, beschermende knop gemaakt van verchromd metaal
- aantal vakken : 11
- .

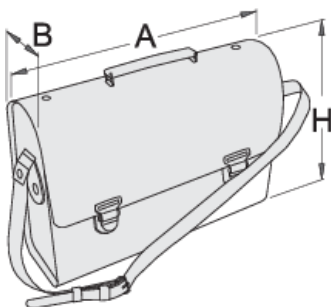

L

B

H





L

B

H



602552

350

110

300

1542

* Afbeeldingen van producten zijn symbolisch. Alle afmetingen zijn in mm en gewicht in gram. Alle vermelde afmetingen kunnen variëren in tolerantie.