

# Electrical bag

909



## Product features

- Material: artificial leather 650 g, pocket walls 450g
- Lock, rings, rivets, buckle, protective knob made from metal, chrome plated
- number of pocket: 28
- .

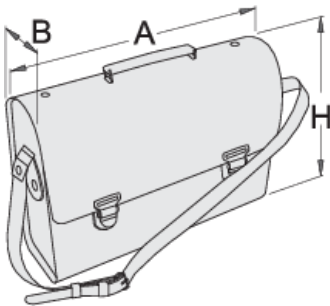

601939

A

420

B

140

H

320



2400

\* Images of products are symbolic. All dimensions are in mm, and weight in grams. All listed dimensions may vary in tolerance.