

# IRONGATOR engineer's vice

721/6





## Profiles

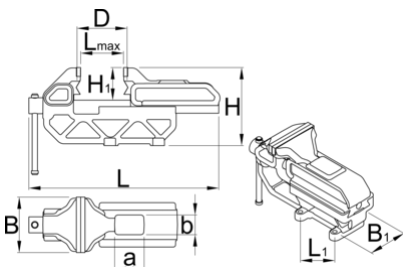

## Product features

- housing from grey iron casting
- drop forged jaws from tool carbon steel, hardened and tempered
- lacquered housing, jaws anticorrosive oiled, other parts zinc plated
- spindle protected against damage
- uniPRO slides ensure precise running of moving parts
- engineer's vice can be combined with swivel base



	B	L↑	L	D	H1	a	b	H	L1	B1	
621564	80	100	215	11 - 35	46	42	28	113	70.4	48	3500
621481	125	160	336	17 - 62	73	66	44	176	110	75	14400
621567	150	190	400	20 - 66	88	80	53	211	132	90	24200
621570	200	220	461	24 - 80	103	93	62	265	154	105	37800

\* Images of products are symbolic. All dimensions are in mm, and weight in grams. All listed dimensions may vary in tolerance.

## Usage (pictures)

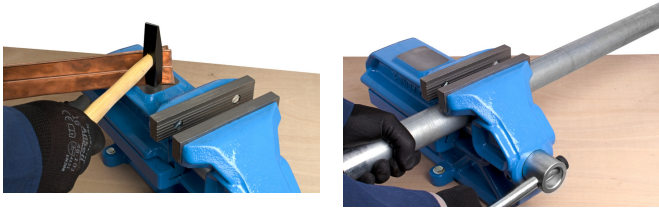

## Accessories



Swivel base for 721/6 and 721Q/6



Spare aluminium jaws for 721/6 and 721Q/6

## Spare parts



Spare jaw for 721/6 and 721Q/6



Spare aluminium jaws for 721/6 and 721Q/6

## Safety tips



- Avoid clamping with heavy pressure on the corner of the vice jaws as it may break off a corner of a jaw.



- Don't use the jaws of a vice as an anvil.

- Replace a bent handle as soon as possible.
- Use bolts in all of the holes in the base of the vice.
- Use lock washers under the nuts.
- When work is held in a vice for sawing, saw as close to the jaws as possible to prevent vibrations. Be careful not to cut into the jaws.
- When clamping extra long work, support the far end of work rather than putting extra pressure on the vice.
- Regularly lightly oil all moving parts.
- If the threaded part of the vice is exposed, keep it free of chips and dirt.
- Discard any vice that exhibits the slightest hairline fracture.
- Always use a vice large enough to hold the work without strain.
- Never use an extension handle for extra clamping pressure.
- Never pound on the handle to tighten beyond hand pressure.
- Never try to repair a vice by welding or brazing.
- Don't try to bend a heavy rod in a light vice.